

VENTSORB®

Powdered Activated Carbon

Description

VENTSORB canisters, each containing 180 pounds of activated carbon, are ideal for low-flow air purification applications at industrial and municipal facilities. These economical adsorption systems control small volume organic contaminants and/or odorous gas emissions from:

- Storage tank vents
- Reactor vents
- API separator vents
- Sludge thickener tanks at waste treatment plants
- Sewer gas vents, wet stations, and weir boxes at chemical and municipal waste treatment plants
- Chemical plant wastewater holding tanks
- Laboratory hood exhausts
- Landfills
- Air-stripper off-gases

The 55-gallon VENTSORB canisters contain all the elements found in a full-scale adsorption system vessel: activated carbon, inlet connection and distributor, and an outlet connection for the purified air stream.

Features

VENTSORB canisters offer industrial and municipal users several important features and benefits including:

- Effective treatment to remove a variety of vapor phase organic contaminants and odor-causing compounds
- Continuous treatment at varying flow rates and concentrations
- Simple installation and operation
- Flexibility to be installed in series or multiple units in parallel
- Supplied with activated carbon selected specifically for the application
- Practical disposal option: pre-approved spent carbon canisters may be returned to Calgon Carbon Corporation for safe carbon reactivation
- Low cost per unit makes carbon treatment economical

Specifications

VENTSORB

Vessel	Open head steel canister
Max. Operating Pressure	4 psig
Cover	Removable steel cover, 12 gauge bolt ring
Internal Coating	Heat-cured phenolic epoxy
External Coating	Baked enamel white
Temperature	140°F (60°C) Continuous 180°F (82°C) intermittent
Inlet	2" FNPT
Outlet	2" FNPT
Max Flow	100 cfm (2.83m ³ /min)
Carbon	180 lbs. AP4-60, BPL 4x10, or VPR
Ship Weight	219 lbs. (99.4 kg)



Applications

Chemical, petrochemical, food, pulp and paper, and many other industrial plants, along with municipal sewage treatment facilities, are frequent users of VENTSORB for continuous control of vented emissions. Examples of user applications include:

Storage Tank Vents

VENTSORB is widely used to control evaporative losses vented from storage tanks. Typically these vapors are emitted during tank filling and emptying. In one application, a glycerin manufacturer uses the canisters to purify ambient air drawn into the storage tanks during product transfer. The adsorption process helps prevent contamination of the company's glycerin product. The VENTSORB units provide greater than six months of service for this application.

Reactor Vents

A pesticide manufacturer is using multiple VENTSORB on five reactor vessels to control trace amounts of odorous methylamine and diethylamine (by-products of a caustic scrubbing process). Each VENTSORB unit handles a 30 cfm air stream containing 15 ppm of amine vapors. The units provide greater than three months of service for this application.

API Separator Vents

A major refinery uses VENTSORB units to control odorous emissions from settling basins where oil is separated from wastewater that is discharged in condensate, blow-down, or drain systems. For this application, API separators are covered and vented to comply with local air pollution control regulations. The air stream is pulled through two VENTSORB units operating in parallel configuration at 100 cfm.

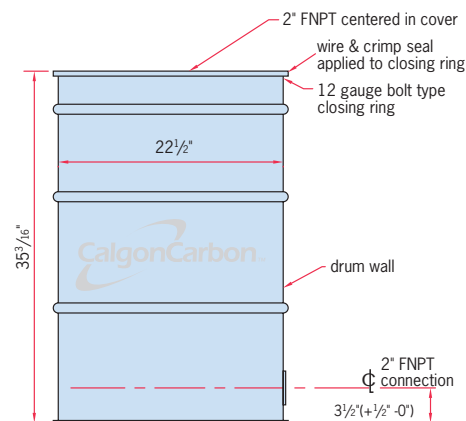

Installation

VENTSORB canisters are shipped ready for installation. Each canister is self-supporting and should be placed on a level, accessible area as near as possible to the emission source. Installation is simple, requiring just a flexible hose or pipe to connect the vent to the 2-inch FNPT bottom inlet of the canister.

If the VENTSORB will be vented directly to outside air, a U-shaped outlet pipe or rain hat (such as a pipe tee) is recommended to prevent precipitation from entering the unit.

VENTSORB canisters operate from a continuous suction across the vent. The suction can be produced by a blower or by using the positive pressure inside the tank or process vessel. In many cases, the pressure or surge of pressure within the tank or vessel is sufficient to overcome the pressure drop across the canister, eliminating the need for a blower. Please consult the pressure drop data in this bulletin for more information.

Maximum recommended air flow through a VENTSORB is 100 cfm. If higher flows are encountered, plant operators should install two or more canisters in parallel configuration. When VENTSORB canisters are used to control vapors from organic solvent storage tanks, the following precautions are recommended:

- A safety relief valve must be provided. This protects the storage tank should the VENTSORB become plugged or blocked in any fashion. Such a vent would open in an emergency situation, thereby relieving pressure.
- Under appropriate conditions a flame arrestor and/or backflow preventor must be installed as shown in this bulletin's storage tank installation drawing. This prevents backflow of air through the VENTSORB when the storage tank is empty.
- Pre-wetting the carbon helps dissipate excessive heat that may be caused by high organic compound concentration (>0.5 to 1.0 Vol.%).

If VENTSORB canisters are used to control organic emissions from air-strippers or other high moisture content air streams, Calgon Carbon Corporation recommends that humidity in the air stream be reduced to under 50 percent. Lower humidity optimizes adsorptive capacity of the carbon. In addition, for similar applications that generate a condensate, Calgon Carbon Corporation recommends installation of a drain on the inlet piping.

Safety Considerations

While complying with recommended installation instructions, plant operators should also be aware of these additional heat-related safety considerations:

- When in contact with activated carbon, some types of chemical compounds, such as those from the ketone and aldehyde families, and some organic acids or organic sulfur compounds, may react on the carbon surface causing severe exotherms or temperature excursions. **If you are unaware or unsure of the reaction of an organic compound on activated carbon, appropriate tests should be performed before placing a VENTSORB in service.**

Typical VENTSORB Installation at Storage Tank

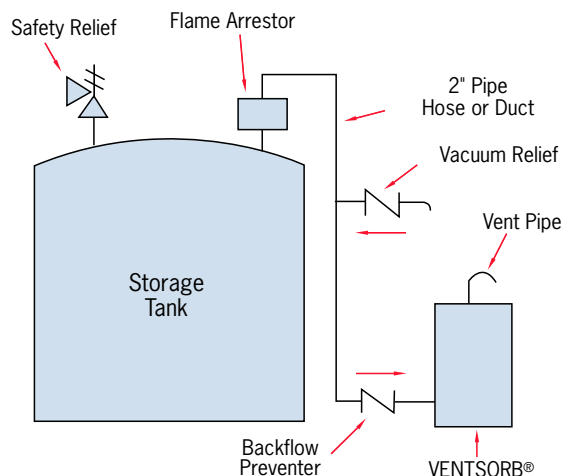

- Heat of adsorption can lead to severe temperature excursions at high concentrations of organic compounds. Heating may be controlled by diluting the inlet air, by time weighting the inlet concentration to allow heat to dissipate, or by pre-wetting the carbon.
- **Do not use VENTSORB with ST1-X carbon in petrochemical or chemical industry applications.**
- ST1-X carbon can liberate heat by reacting chemically with oxygen. To prevent heat within a vessel, the carbon must not be confined without adequate air flow to dissipate the heat. In situations where there is insufficient or disrupted air flow through the vessel, the chemical reaction can be prevented by sealing the inlet and outlet connections to the vessel.

Safety Considerations

For temperatures greater than 140°F, Calgon Carbon recommends that personnel protection be provided. The form of protection is determined per the end user's specific plant practices and standards. Also note that at elevated temperatures, the paint may discolor.

Safety Message

Wet activated carbon preferentially removes oxygen from air. In closed or partially closed containers and vessels, oxygen depletion may reach hazardous levels. If workers are to enter a vessel containing carbon, appropriate sampling and work procedures for potentially low oxygen spaces should be followed, including all applicable Federal and State requirements.

Return of VENTSORB

Arrangements should be made at the time of purchase to return canisters containing spent carbon. Calgon Carbon Corporation can provide instructions on how to sample the spent carbon and arrange for carbon acceptance testing. The spent carbon is reactivated by Calgon Carbon Corporation, and all of the contaminants are thermally destroyed. Calgon Carbon Corporation will not accept VENTSORB canisters for landfill, incineration, or other means of disposal.

Pressure Drop

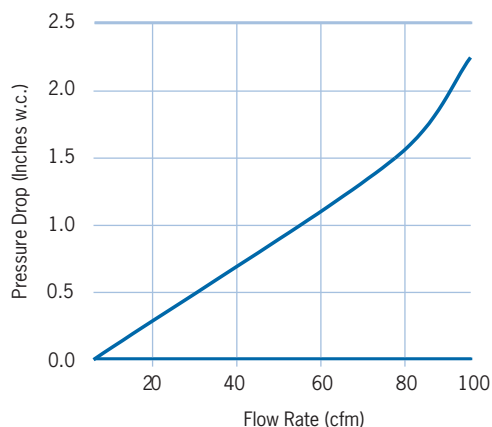

VENTSORB cannot be returned to the company unless the carbon acceptance procedure has been completed, an acceptance number provided, and the return labels (included with the unit at the time of purchase) are attached.

VENTSORB must be drained and inlet/outlet connections must be plugged prior to return to Calgon Carbon Corporation. Pressure drop through a VENTSORB unit is a function of the process air flow as shown in the graph. A VENTSORB canister can handle up to 100 cfm at a pressure drop of less than 2.5 inches of water column. If higher flows or lower pressure drop is needed, multiple canisters may be installed in parallel operation. The maximum canister pressure should not exceed 4 psig.

Calgon Carbon Air Purification Systems

VENTSORB is specifically designed for a variety of small applications. Calgon Carbon Corporation offers a wide range of carbon adsorption systems and services for a range of flow rates and carbon usages to meet specific applications.

Carbon Life Estimate

This table lists the theoretical adsorption capacities for several compounds. The adsorption capacity for nonpolar organic compounds increases with the boiling point, molecular weight, and concentration of the air contaminant. Estimate the life of a VENTSORB canister for other organic compounds by matching them with compounds of similar boiling points and molecular weight in this table. Low molecular weight (less than 50) and/or highly polar compounds such as formaldehyde, methane, ethanol, etc. will not be readily adsorbed at low concentrations.

Note: The standard VENTSORB canister contains 180 pounds of AP4-60 carbon. When removing hydrogen sulfide and mercaptans from moist air vented from sewage operations, greater efficiency will be achieved by using a VENTSORB canister which contains specially impregnated ST1-X carbon. A VENTSORB containing ST1-X carbon can remove up to 40 pounds of hydrogen sulfide and 15 pounds of methyl mercaptan.

Theoretical Capacities*

Pounds Adsorbed per VENTSORB at Given Concentration of Contaminant

	Boiling Point (°C)	Molecular Weight (g)	Lbs. @ 10 ppm	Lbs. @ 100 ppm	Lbs. @ 1,000 ppm
Acrylonitrile	77.3	53.1	6	12	24
Benzene	80.1	78.1	14	23	36
n-Butane	-0.5	58.1	4	8	13
Carbon Tetrachloride	76.8	153.8	40	56	76
Dichloroethylene	37.0	97.0	12	21	35
Methylene	40.2	84.9	3	7	18
Freon 114	3.8	170.9	11	19	33
n-Hexane	68.7	86.2	18	25	34
Styrene	145.2	104.1	45	57	71
Toluene	110.6	92.1	34	44	58
Trichloroethylene	87.2	131.4	33	50	73

* Theoretical capacity based on 70° F, 1 atm pressure, less than 50 percent humidity, and 180 pounds of carbon using isotherm data for AP4-60 carbon.

Warranty

Calgon Carbon Corporation warrants that the VENTSORB canister will be free from defects in materials and workmanship for a period of 90 days following the date of purchase. In the event of a breach of this warranty, Calgon Carbon Corporation will, in its discretion, repair or replace any defective parts or the complete unit during the warranty period. This warranty does not apply to defects caused by (i) normal wear and tear, (ii) accident, disaster or event of force majeure, (iii) misuse, fault or negligence of or by Buyer, (iv) use of the VENTSORB canister in a manner for which it is not designed, (v) use of media in the VENTSORB canister not supplied by Calgon Carbon Corporation, (vi) external causes such as, but not limited to, power failure or electrical power surges, or (v) improper storage and handling of the VENTSORB canister. **Except as expressly provided in this warranty statement, Calgon Carbon Corporation disclaims all other warranties, whether express or implied, oral or written, including without limitations all implied warranties or merchantability or fitness for particular purpose. Calgon Carbon Corporation does not warrant that the VENTSORB canisters are error-free or will accomplish any particular result. Any advice or assistance furnished by Calgon Carbon Corporation in relation to the VENTSORB canister provided for hereunder shall not give rise to any warranty or guarantee of any kind. This warranty will take precedence over any and all other warranties unless specifically disclaimed and referenced by Calgon Carbon Corporation.**

Limitation of Liability

Calgon Carbon Corporation' liability and the Buyer's exclusive remedy for any cause of action arising out of this transaction, including, but not limited to, breach of warranty, negligence and/or indemnification, is expressly limited to a maximum of the purchase price of the VENTSORB canister sold hereunder. All claims of whatsoever nature shall be deemed waived unless made in writing within forty-five (45) days of the occurrence giving rise to the claim. Under no circumstance shall Calgon Carbon Corporation be liable for any incidental, consequential, punitive, exemplary, or special damages of any kind arising as a result of or in connection with the VENTSORB canisters, regardless of the cause giving rise to any claim. Nor shall Calgon Carbon Corporation be liable for loss of profits or fines imposed by governmental agencies. In no event shall Calgon Carbon Corporation's liability exceed the purchase price paid by purchaser, for any reason, whether by reason of breach of contract, tort, indemnification, warranty, or otherwise. This limitation of this liability statement will take precedence over any and all other liability provisions unless specifically disclaimed and referenced by Calgon Carbon Corporation.

Making Water and Air Safer and Cleaner

www.calgoncarbon.com



Corporate Headquarters
Calgon Carbon Corporation
500 Calgon Carbon Drive
Pittsburgh, PA USA 15205
1-800-422-7266
Tel: 1-412-787-6700
Fx: 1-412-787-6713

www.calgoncarbon.com

Chemviron Carbon
Zoning Industriel C de Feluy
B-7181 Feluy, Belgium
Tel: + 32 (0) 64 51 18 11
Fx: + 32 (0) 64 54 15 91

Your local representative