

## Description

VENTSORB® PE canister, containing 180 pounds of activated carbon, is ideal for low-flow treatment applications. These economical adsorption systems control small volume organic contaminants and/or odorous gas emissions from:

- Storage tank vents
- Reactor vents
- API separator vents
- Sludge thickener tanks at waste treatment plants
- Chemical plant wastewater holding tanks
- Laboratory hood exhausts
- Landfills
- Air-stripper off-gases

The 55-gallon VENTSORB® PE canister contains all the elements found in a full-scale adsorption system vessel: activated carbon, inlet connection and distributor, and an outlet connection for the purified air stream.



## Features

VENTSORB® PE canisters offer several important features and benefits including:

- Effective treatment to remove a variety of vapor phase organic contaminants and odor-causing compounds
- All plastic construction for reliable non-corrosive service
- Continuous treatment at varying flow rates and concentrations
- Simple installation and operation
- Flexibility to be installed in series or multiple units in parallel
- Supplied with activated carbon selected specifically for the application
- Practical disposal option: pre-approved spent carbon canisters may be returned to Calgon Carbon Corporation for safe carbon reactivation
- Low cost per unit makes carbon treatment economical

## Activated Carbon Selection

The standard VENTSORB® PE is provided with Calgon Carbon's bituminous coal-based AP4-60 4 mm pellet activated carbon. Calgon Carbon offers a wide variety of activated carbons for special applications that can be used in the VENTSORB® PE. Contact Calgon Carbon for more information on other activated carbon products.

## Typical Carbon Products Available

VPR	Reactivated Grade Vapor Phase Carbon
AP4-60	Virgin Grade Vapor Phase Carbon—4 mm Pellet
BPL 4X10	Virgin Grade Vapor Phase Carbon—Granular 4X10 Mesh

## Pressure Drop

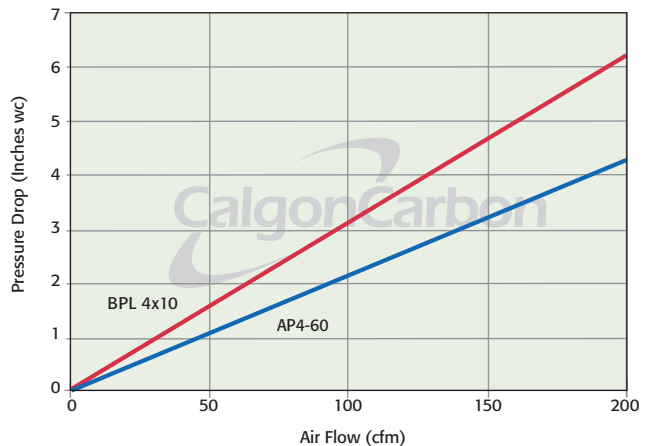

Pressure drop through a VENTSORB® PE unit is a function of the process air flow as shown in the graph. A VENTSORB® PE canister can handle up to 200 cfm at a pressure drop of less than 6 inches of water column. If a higher flow or lower pressure drop is needed, multiple canisters may be installed in parallel operation. The maximum canister pressure should not exceed 2 psig.

## Materials of Construction

Canister	Open top 55 gallon plastic drum 125 mil thick (min) HMW-high density polyethylene
Cover	175 mil thick HMW-HDPE with closure and polyurethane gasket
Inlet/Outlet Fittings	4" diameter FNPT polyethylene coupling
Internal Distributor	High density polyethylene
Inlet/Outlet Shipping Plugs	PVC, threaded
Weight Empty	24 lbs.
Carbon Load	180 lbs.
Operating Temperature	120° F maximum

## Drum Dimensions

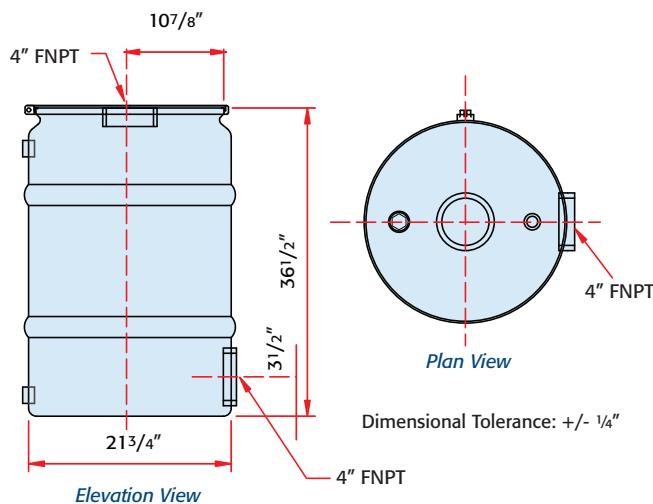

## Installation

VENTSORB® PE canisters are shipped ready for installation. Each canister is self-supporting and should be placed on a level, accessible area as near as possible to the emission source. Installation is simple, requiring just a flexible hose or pipe to connect the source to the 4" FNPT bottom inlet of the canister.

If the VENTSORB® PE will be vented directly to outside air, a U-shaped outlet pipe or rain hat (such as a pipe tee) is recommended to prevent precipitation from entering the unit.

VENTSORB® PE canisters operate from a continuous flow across the carbon. The flow can be produced by a blower or by using the positive pressure inside the tank or process vessel. In many cases, the pressure or surge of pressure within the tank or vessel is sufficient to overcome the pressure drop across the canister, thus eliminating the need for a blower. Please consult the pressure drop data in this bulletin for more information.

Maximum recommended air flow through a VENTSORB® PE is 200 cfm. If higher flows are encountered, plant operators should install two or more canisters in parallel configuration.

When VENTSORB® PE canisters are used to control vapors from organic solvent storage tanks, (see drawing of typical installation) the following precautions are recommended:

## Storage Tank Installation

- A safety relief valve must be provided. This protects the storage tank should the VENTSORB® PE become plugged or blocked in any fashion. Such a vent would open in an emergency situation, thereby relieving pressure.
- Under appropriate conditions, a flame arrestor and/or backflow preventor must be installed as shown in the storage tank installation drawing below. This prevents backflow of air through the VENTSORB® PE when the storage tank is empty.
- Pre-wetting the carbon helps dissipate excessive heat that may be caused by high organic compound concentrations (>0.5 to 1.0 Vol.%).

If VENTSORB® PE canisters are used to control organic emissions from air-strippers or other high moisture content air streams, Calgon Carbon Corporation recommends that humidity in the air stream be reduced to under 50 percent. Lower humidity optimizes adsorptive capacity of the carbon. In addition, for similar applications that generate a condensate, Calgon Carbon Corporation recommends installation of a drain on the inlet piping.

## Typical Installation at a Storage Tank

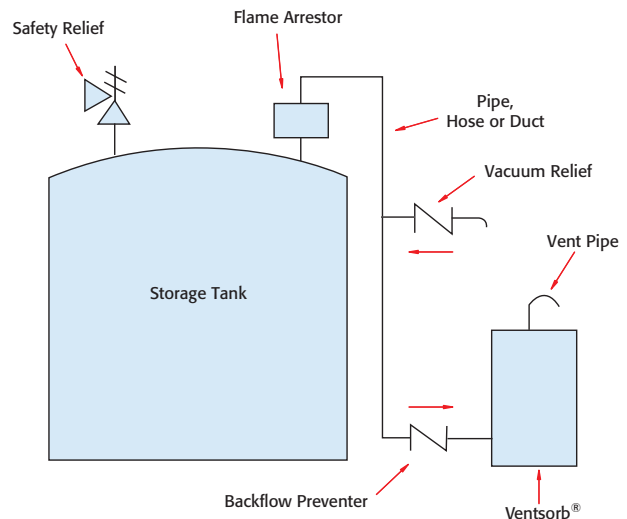

## Carbon Life Estimate

The below table lists the theoretical adsorption capacities for several compounds. The adsorption capacity for non-polar organics increases with the boiling point, molecular weight, and concentration of the air contaminant. Estimate the life of a VENTSORB® PE canister for other organic compounds by matching them with compounds of similar boiling points and

molecular weight in this table. Low molecular weight (less than 50) and/or highly polar compounds such as formaldehyde, methane, ethanol, etc. will not be readily adsorbed at low concentrations.

## Theoretical VENTSORB® PE Capacities\*

*Pounds Adsorbed per VENTSORB® PE at Given Concentration of Contaminant*

	Boiling Point (°C)	Molecular Weight (g)	Lbs. @ 10 ppm	Lbs. @ 100 ppm	Lbs. @ 1,000 ppm
Acrylonitrile	77.3	53.1	6	12	24
Benzene	80.1	78.1	14	23	36
n-Butane	-0.5	58.1	4	8	13
Carbon Tetrachloride	76.8	153.8	40	56	76
Dichloroethylene	37.0	97.0	12	21	35
Methylene	40.2	84.9	3	7	18
Freon 114	3.8	170.9	11	19	33
n-Hexane	68.7	86.2	18	25	34
Styrene	145.2	104.1	45	57	71
Toluene	110.6	92.1	34	44	58
Trichloroethylene	87.2	131.4	33	50	73

\* Theoretical capacity based on 70°F, 1 atm pressure, less than 50 percent humidity, and 180 pounds of carbon using isotherm data for AP4-60 carbon.

## Return of VENTSORB® PE

Arrangements should be made at the time of purchase to return canisters containing spent carbon. Calgon Carbon Corporation can provide instructions on how to sample the spent carbon and arrange for carbon acceptance testing. The spent carbon is reactivated by Calgon Carbon Corporation and all of the contaminants are thermally destroyed. Calgon Carbon Corporation will not accept VENTSORB® PE for landfill, incineration, or other means of disposal.

VENTSORB® PE cannot be returned to the company unless the carbon acceptance procedure has been completed, an acceptance number provided, and the return labels (included with the unit at the time of purchase) are attached.

VENTSORB® PE must be drained and inlet/outlet connections must be plugged prior to returning the unit to Calgon Carbon Corporation.

## Other Air Purification Systems

VENTSORB PE® is specifically designed for a variety of small applications. Calgon Carbon Corporation offers a wide range of carbon adsorption systems and services for a range of flow rates and carbon usages to meet specific applications.

## Safety Considerations

Continuous process temperatures above 120° F are to be avoided.

High concentrations of Hydrogen Sulfide and VOC's could cause excessive heat build-up. Care must be exercised in the design of the treatment system for flammable gases or reactive vapors.

The use of a pressure safety relief, flame arrestor and/or backflow device is recommended for installations venting storage tanks.

VENTSORB® PE units with Centaur® HSV carbon that are washed with water produce a dilute acid that must be handled appropriately.

Slight pressure may accumulate in a sealed VENTSORB® PE canister due to extreme changes in ambient temperature conditions. Use care when removing the plastic shipping plugs.

Activated carbon may cause an exothermic reaction in the presence of oxygen bearing compounds, such as peroxides, ketones, organic acids, aldehydes and also organic sulphur compounds. The introduction of flammable compounds into the unit while an exothermic reaction is occurring will ignite the gas stream causing fire and explosion. Flooding the unit with water will extinguish the flames but generate steam and pressure. USE CAUTION!

Heat of adsorption can lead to severe temperature excursions at high concentrations of organic compounds. Heating may be controlled by diluting the inlet air, by time weighting the inlet concentration to allow heat to dissipate, or by pre-wetting the carbon.

If you are unsure of the reaction of an organic compound on activated carbon or have other questions, please contact a Calgon Carbon Corporation Application Engineer or Sales Representative.

## Safe Handling and Storage of Wet Carbon

Wet activated carbon preferentially removes oxygen from air. In closed or partially closed containers and vessels, oxygen depletion may reach hazardous levels. If workers are to enter a vessel containing carbon, appropriate sampling and work procedures for potentially low oxygen spaces should be followed, including all applicable Federal and State requirements.

## Warranty

Calgon Carbon Corporation warrants that the VENTSORB PE canister will be free from defects in materials and workmanship for a period of 90 days following the date of purchase. In the event of a breach of this warranty, Calgon Carbon Corporation will, in its discretion, repair or replace any defective parts or the complete unit during the warranty period. This warranty does not apply to defects caused by (i) normal wear and tear, (ii) accident, disaster or event of force majeure, (iii) misuse, fault or negligence of or by Buyer, (iv) use of the VENTSORB PE canister in a manner for which it is not designed, (v) use of media in the VENTSORB PE not supplied by Calgon Carbon Corporation, (vi) external causes such as, but not limited to, power failure or electrical power surges, or (v) improper storage and handling of the VENTSORB PE canister. **Except as expressly provided in this warranty statement, Calgon Carbon Corporation disclaims all other warranties, whether express or implied, oral or written, including without limitations all implied warranties or merchantability or fitness for particular purpose. Calgon Carbon Corporation does not warrant that the VENTSORB PE canisters are error-free or will accomplish any particular result. Any advice or assistance furnished by Calgon Carbon Corporation in relation to the VENTSORB PE canister provided for hereunder shall not give rise to any warranty or guarantee of any kind. This warranty will take precedence over any and all other warranties unless specifically disclaimed and referenced by Calgon Carbon Corporation.**

## Limitations of Liability

Calgon Carbon Corporation' liability and the Buyer's exclusive remedy for any cause of action arising out of this transaction, including, but not limited to, breach of warranty, negligence and/or indemnification, is expressly limited to a maximum of the purchase price of the VENTSORB PE canister sold hereunder. All claims of whatsoever nature shall be deemed waived unless made in writing within forty-five (45) days of the occurrence giving rise to the claim. Under no circumstance shall Calgon Carbon Corporation be liable for any incidental, consequential, punitive, exemplary, or special damages of any kind arising as a result of or in connection with the VENTSORB PE canisters regardless of the cause giving rise to any claim. Nor shall Calgon Carbon Corporation be liable for loss of profits or fines imposed by governmental agencies. In no event shall Calgon Carbon Corporation's liability exceed the purchase price paid by purchaser, for any reason, whether by reason of breach of contract, tort, indemnification, warranty or otherwise. This limitation of liability statement will take precedence over any and all other liability provisions unless specifically disclaimed and referenced by Calgon Carbon Corporation.



Making Water and Air Safer and Cleaner

Calgon Carbon Corporation  
P.O. Box 717  
Pgh, PA USA 15230-0717  
1-800-422-7266  
Tel: 1-412-787-6700  
Fx: 1-412-787-6713

Chemviron Carbon  
European Operations of  
Calgon Carbon Corporation  
Zoning Industriel C de Feluy  
B-7181 Feluy, Belgium  
Tel: + 32 (0) 64 51 18 11  
Fx: + 32 (0) 64 54 15 91

Calgon Carbon Asia PTE LTD  
9 Temasek Boulevard  
#08-01A Suntec Tower Two  
Singapore 038989  
Tel: + 65 6 221 3500  
Fx: + 65 6 221 3554

## Your local representative