

## Description

Designed for low-flow water treatment applications, prefabricated 55-gallon FLOWSORB® canisters contain all the operating elements found in a full-scale adsorption system. These small, economical treatment systems hold 180 pounds of granular activated carbon for applications including:

- Small wastewater streams
- Groundwater remediation
- Underground storage tank leaks
- Well pump tests
- Product purification or de-colorization
- Tank cleaning water treatment
- Batch water or product treatment
- Carbon adsorption pilot testing
- Emergency spill treatment
- Monitoring well water treatment

## Features

FLWSORB® offers several features and benefits to industrial, commercial, and municipal users including:

- Low cost per unit makes carbon treatment economical
- Simple installation and operation
- Space above carbon bed facilitates flow distribution or back-flushing
- Flexibility to be used in series or parallel operation
- Supplied with virgin or reactivated carbon
- Practical disposal option: pre-approved spent carbon canisters may be returned to Calgon Carbon Corporation for safe carbon reactivation
- Continuous treatment at various flow rates and concentrations

## Pressure Drop

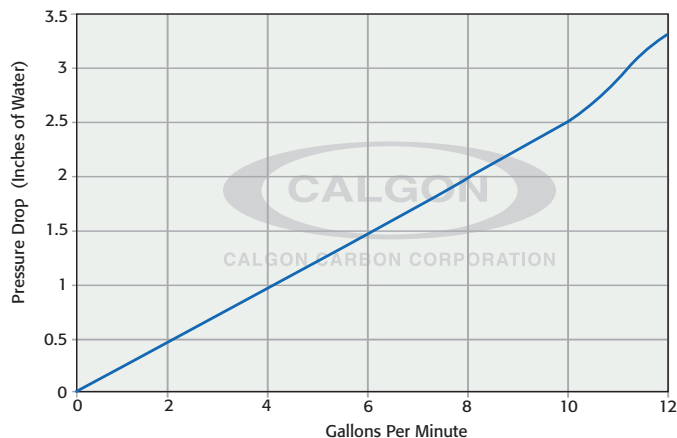

## Specifications

|                   |  |
|-------------------|--|
| Vessel            | Open head steel canister   |
| Cover             | Removable steel cover, 12 gauge bolt ring  |
| Internal Coating  | Heat-cured phenolic epoxy  |
| External Coating  | Baked enamel (white)   |
| Temperature Limit | 150°F (65.6°C) continuous<br>250°F (121.1°C) intermittent                        |
| Inlet             | 2" FNPT  |
| Outlet            | 2" FNPT  |
| Carbon            | 180 lbs. granular activated carbon: Specify FILTRASORB® 300 or reactivated grade |
| Ship Weight       | 219 lbs. (99.4 kg)   |
| Identification    | Sequentially numbered for traceability   |

## Typical Operating Parameters

|                     |   |
|---------------------|---|
| Flow Rate           | 10 gpm (37.8 l/m)                       |
| Contact Time        | 4.5 minutes                             |
| Pressure Drop       | < 1 psi (clean water and carbon)        |
| Operating Pressures | Recommend operation at less than 5 psig |



**Installation**

FLAWSORB® canisters are shipped with dry activated carbon; the carbon must be wetted and de-aerated prior to use. This procedure displaces air from the internal structure of the carbon granule, thus assuring that the liquid to be treated is in contact with the carbon surface.

Prior to operation each canister must be filled with clean water; the water should be introduced into the bottom outlet connection. The unit should sit for approximately 48 hours to allow most of the carbon's internal surface to become wetted as shown on the wetting curve.

After wetting, the carbon bed can be de-aerated by draining the canister and refilling the canister upflow with clean water. This procedure will eliminate any air pockets which may have formed between the carbon granules. The FLAWSORB® is now ready for operation.

Canisters should be set on a flat, level surface and piped as recommended in the installation illustration. The influent pipe connection should be attached to the unit by using a flexible connection. Some minor deflection of the lid may occur if pressure builds due to filtration or other flow blockage downstream.

FLAWSORB® discharge piping should include an elevated piping loop to ensure that the canister remains flooded with water at all times. In addition to the piping loop, a drain connection is recommended on the discharge piping; this allows drainage of the unit prior to disconnection or temporary shut-down.

A filter should be installed if the liquid to be treated contains substantial amounts of suspended solids. A simple cartridge or screen filter helps prevent pressure buildup in the carbon bed.

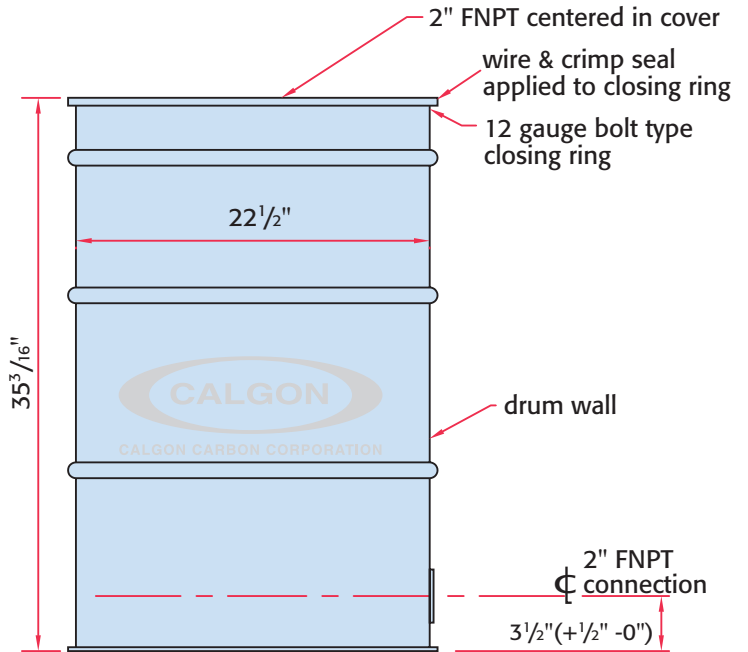

**Typical Installation**

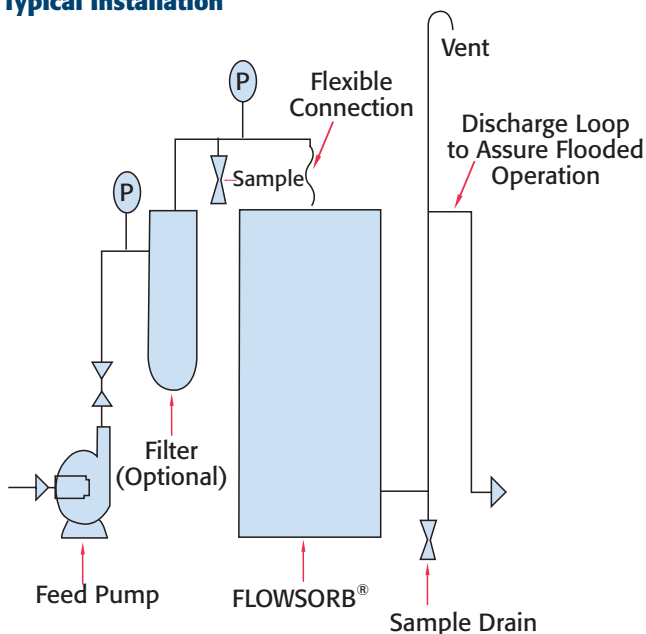

**Wetting Curve for GAC (77°F/25°C)**

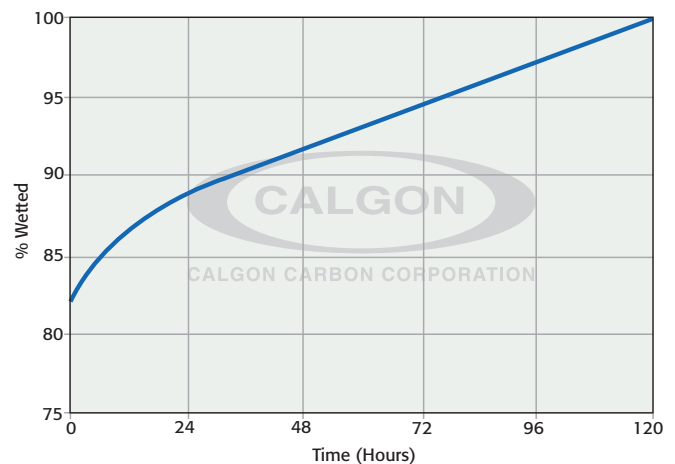

**Operation**

FLWSORB® canisters should be full of clean water before treatment begins. Flow rate to the canister should be determined based on required contact time between the liquid and the carbon media. In groundwater treatment applications, the recommended contact time is typically 8-10 minutes with a resultant flow of approximately 5 gpm. Consult your Calgon Carbon Corporation Technical Sales Representative for advice about proper contact time for your application.

FLWSORB® can be manifolded in parallel operation for higher flow rates. For series operation, two FLWSORB® can be piped together sequentially, as normal pressure drop will not exceed the recommended operating pressure.

These canisters have space for bed expansion and can be back flushed by introducing clean water or liquid at approximately 20-25 gpm to the outlet and taking backflush water from the inlet.

**How to Estimate FLWSORB® Life**

The treatment table on this page lists the volume of water that can be purified by the FLWSORB® for typical contamination situations. Most applications, however, involve a unique mixture of organic chemical contaminants including some chemicals that adsorb at different capacities or strengths. Please consult with your Calgon Carbon Technical Sales Representative for more information about carbon usage rates.

**Calgon Carbon Liquid Purification System**

FLWSORB® is a unit specifically designed for a variety of small flow applications. Calgon Carbon Corporation offers a wide range of carbon adsorption systems and services for a greater range of flow rates and carbon usages to meet specific applications.

**Return of FLWSORB®**

Arrangements should be made at the time of purchase to return canisters containing spent carbon. Calgon Carbon will provide instructions on how to sample the spent carbon and arrange for carbon acceptance testing. The spent carbon is reactivated by Calgon Carbon and all of the contaminants are thermally destroyed. The company will not accept FLWSORB® for landfill, incineration, or other means of disposal.

FLWSORB® cannot be returned to Calgon Carbon unless the carbon acceptance procedure has been completed, an acceptance number provided, and the return labels (included with the unit at the time of purchase) are attached. FLWSORB® must be drained and inlet/outlet connections must be plugged prior to return to Calgon Carbon.

**Theoretical Treatment Capacity for Typical Cases**

|           | <b>Case 1<br/>1,600,000 Gallons</b> | <b>Case 2<br/>400,000 Gallons</b> | <b>Case 3<br/>85,000 Gallons</b>  |
|-----------|-------------------------------------|-----------------------------------|-----------------------------------|
| Benzene   | 20 ppb                              | 200 ppb                           | 2 ppm                             |
| Toluene   | 40 ppb                              | 400 ppb                           | 4 ppm                             |
| Xylene    | 40 ppb                              | 400 ppb                           | 4 ppm                             |
|           | <b>Case 4<br/>1,900,000 Gallons</b> | <b>Case 5<br/>550,000 Gallons</b> | <b>Case 6<br/>125,000 Gallons</b> |
| TCE       | 50 ppb                              | 500 ppb                           | 5 ppm                             |
| PCE       | 50 ppb                              | 500 ppb                           | 4 ppm                             |
|           | <b>Case 7<br/>230,000 Gallons</b>   | <b>Case 8<br/>50,000 Gallons</b>  | <b>Case 9<br/>10,000 Gallons</b>  |
| Phenol    | 1 ppm                               | 10 ppm                            | 100 ppm                           |
| Total SOC | 10 ppm                              | 100 ppm                           | 1,000 ppm                         |

Each case represents a groundwater or wastewater stream that contains the combination of contaminants listed. The treatment capacity indicates the total gallons of that particular water that may be treated before any of the specific contaminants are present in the treated water as noted. Theoretical capacity based on 5 gpm water at 70°F or less and 180 lbs. of FILTRASORB® 300. Background TOC is < 1 ppm except phenol cases as noted. Contaminants reduced to < 5 ppb except phenol case which is for 95% phenol reduction.

**Warranty**

There are no expressed or implied warranties or any warranty of merchantability or fitness for a particular purpose associated with the sale of this product.

**Safety Message**

It is unlikely that a worker would be able to physically enter a FLOWSORB® canister; however, the following information and precautions apply to partially closed canisters or situations where carbon is to be removed from the canister and stored elsewhere.

Wet activated carbon preferentially removes oxygen from air. In closed or partially closed containers and vessels, oxygen depletion may reach hazardous levels. If workers are to enter a vessel containing carbon, appropriate sampling and work procedures for potentially low oxygen spaces should be followed including all applicable federal and state requirements.



CALGON CARBON CORPORATION

Calgon Carbon Corporation  
P.O. Box 717  
Pittsburgh, PA USA 15230-0717  
1-800-422-7266  
Tel: 1-412-787-6700  
Fx: 1-412-787-6713

Making Water and Air Safer and Cleaner

Chemviron Carbon  
European Operations of  
Calgon Carbon Corporation  
Zoning Industriel C de Feluy  
B-7181 Feluy, Belgium  
Tel: + 32 (0) 64 51 18 11  
Fx: + 32 (0) 64 54 15 91

Calgon Carbon Asia PTE LTD  
9 Temasek Boulevard  
#08-01A Suntec Tower Two  
Singapore 038989  
Tel: + 65 6 221 3500  
Fx: + 65 6 221 3554

**Your local representative**