

C³150™ PS

Packaged Ultraviolet Disinfection System



Description

The Calgon Carbon Corporation C³150™ PS packaged UV disinfection system product line is an advanced, cost-effective solution for the disinfection of wastewater. This state-of-the-art UV disinfection system is intended for plants with flows of 50,000 gallons per day to 1 MGD (200 to 3,800 m³ per day).

The C³150™ PS UV disinfection system is prepackaged for quick and easy installation. The design uses a rugged modular concept that simplifies operation and routine maintenance by operations personnel. The complete prepackaged UV system includes lamp racks, stainless steel channel, power distribution center and all necessary interconnecting cables.

It is designed for simple installation and trouble-free operation throughout the life of the system. The C³150™ PS is designed to operate at temperatures ranging from 14°–104°F (-10°–40°C) with 5–95% relative humidity (non-condensing). System modifications are available for conditions outside of this range.

Design Features

Completely Prepackaged

- Includes all components required for operating a UV disinfection system
- Includes a prefabricated stainless steel channel with a level control weir and preassembled quick-connect cables for simple installation and system start-up

Lamp Technology

- Low-pressure, high-output (LPHO) lamp technology
- Rapid-start continuous heat configuration

Ballast Technology

- Efficient, high frequency electronic ballast
- Variable output
- Each ballast powers two LPHO lamps

Automatic Cleaning System

- Mechanical, non-chemical cleaning
- Automatic or manual initiation

Innovative Control System

- Dose or flow pacing
- Self-diagnostics
- Lamp status indication
- Elapsed time counter
- Remote annunciation of alarms and bank status

UV Intensity Sensor

- Monitors the average intensity within the lamp bank array
- User adjustable setpoints for low and low-low UV Intensity alarms

Input Power Options

- 208 / 120VAC, 3 Phase, 4 Wire and GND, 60 Hz
- 380 / 220VAC, 3 Phase, 4 Wire and GND, 50 / 60 Hz
- 415 / 240VAC, 3 Phase, 4 Wire and GND, 50 / 60 Hz

Power Demand

- 170 watts/lamp including ballast (nominal)

Power Quality

- System Power Factor is 0.95 minimum

Options

- Magnetic Flow Meter
- Portable Photometer
- Service Trolley



C³150™ PS

Packaged Ultraviolet Disinfection System



Flows, Power Demands and Dimensions

The table below outlines some typical C³150™ wastewater disinfection systems for a range of flow rates.

Systems will vary to suit site-specific requirements. These models are based on a UV transmission of 65%, 15 mg/L of suspended solids, and a disinfection limit of 200 fecal coliforms per 100 mL.

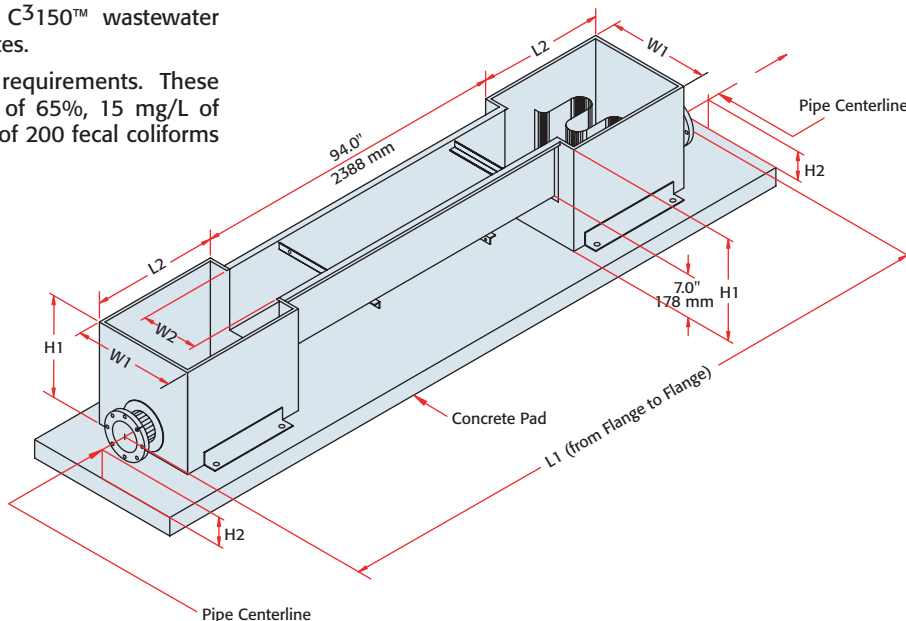

C³150™ PS Packaged System Details

Model Number	Peak Flow		No. of Lamps	Power Demand (Watts)	Dimensions (mm / inches)						Flange Size ¹⁾		Weight (kg/lbs) approx.
	m ³ /day	gal/day x 1000			L1	L2	W1	W2	H1	H2	Inlet (inches)	Outlet (inches)	
C3-10125P	475	125	2	350	3861	610	406	178	521	95	3	3	142
					152.0	24.0	16.0	7.0	20.5	3.75			312
C3-10250P	950	250	4	700	4064	711	762	178	610	140	6	6	208
					160.0	28.0	30.0	7.0	24.0	5.5			458
C3-10375P	1,425	375	6	1,050	4064	711	762	178	699	140	6	6	236
					160.0	28.0	30.0	7.0	27.5	5.5			519
C3-10500P	1,900	500	8	1,400	4064	711	762	178	787	140	6	6	265
					160.0	28.0	30.0	7.0	31.0	5.5			584
C3-10750P	2,850	750	12	2,100	4470	914	1016	356	699	171	8	8	352
					176.0	36.0	40.0	14.0	27.5	6.75			775
C3-11000P	3,800	1,000	16	2,800	4470	914	1016	356	787	171	8	8	413
					176.0	36.0	40.0	14.0	31.0	6.75			909

¹⁾ Flange size: ANSI 150# stainless steel, slip-on type.
Please contact factory for dimensions applicable to concrete channel.



CALGON CARBON CORPORATION

Calgon Carbon Corporation
P.O. Box 717
Pittsburgh, PA USA 15230-0717
1-800-422-7266
Tel: 412-787-6700
Fx: 412-787-6713

Making Water and Air Safer and Cleaner

Chemviron Carbon
European Operations of
Calgon Carbon Corporation
Zoning Industriel C de Feluy
B-7181 Feluy, Belgium
Tel: + 32 (0) 64 51 18 11
Fx: + 32 (0) 64 54 15 91

Calgon Carbon Asia
65 Chulia Street
#37-03 OCBC Centre
Singapore 049513
Tel: +65 6 221 3500
Fx: +65 6 221 3554

Your local representative

